

INSTRUCTION MANUAL

MECHANICAL DIESEL METER

AMFM



MECHANICAL DIESEL METER

AMFM

INTRODUCTION

Thank you for purchasing a Macnaught AMFM Mechanical Diesel Meter

The AMFM meter is a mechanical nutating disc meter providing a reliable, accurate method of measuring diesel. The meter has two totals available (resettable batch total and non-resettable total).

Macnaught manufacture a full range of pumps, meters and accessories to suit most of your fluid transfer needs. Please consult your local Macnaught reseller for more information.

Please read and retain this instruction manual to assist you in the operation and maintenance of this quality product.

GENERAL INFORMATION

This manual assists you in operating and maintaining your new Mechanical Diesel Meter. The information contained will help you ensure many years of dependable performance and trouble free operation.

Your in-line nutating meter is designed to accurately measure low viscosity fluids and water. This nutating disc meter is ideal for use on low pressure in-line applications, mobile installations and electric diesel pumps, generally fitted close to the dispensing nozzle

CAUTION

Observe precautions against fire or explosion when dispensing flammable liquid. Do not operate the meter in the presence of any source of ignition including running or hot engines, lighted cigarettes or gas or electric heaters.

Ensure that you follow all the correct earthing and grounding procedures before use.

Inspect seals and connections for leaks weekly when using flammable liquids.

Do not use Teflon tape on any connections when using flammable liquid.

Do not use this meter with gasoline or any fluid other than the compatible fluid specified in this manual.

Do not use the meter above the maximum pressure of 3.5 bar



OPERATION

Both the batch total and accumulative total will turn simultaneously when fluid passes through the meter.

Turn the reset knob to reset the batch total to zero

INSTALLATION

The meter has been manufactured for standard horizontal fitting with a flow direction from left to right. The orientation can be changed using the following procedure.

1. Remove the 4 screw on the underside of the meter.
2. Turn the body to the desired location.
3. Carefully fit the register to the meter body, ensure you do not damage the sealing body o'ring.
4. Replace and tighten the 4 screws.

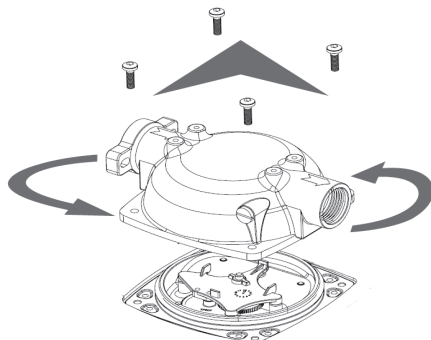

NOTE: When fitting meter, ensure direction of flow is the same as the arrow cast to underside of the meter.

Macnaught recommends that a filter screen of at least 40 mesh is installed prior to the flow meter. Macnaught has a HA1S (10 micron) fuel filter available if required.

DO NOT exceed a maximum pressure of 3.5 bar (50psi)

MECHANICAL DIESEL METER

AMFM

METER FIELD CALIBRATION

Calibration may be required depending on installation or after disassembly, metering different fluids or where meter wear has occurred.

NOTE: You will need to use an accurate measuring container with graduations up to at least 19 litre capacity.

Calibration procedure

1. Set the batch total to Zero
2. Dispense 19 liters into your accurate measuring container
3. Check the total shown on the meter and compare with the actual total dispensed as shown in the container.
4. Adjust the calibration screw as required
 - a) Turn the screw anti-clockwise to reduce the indicated amount
 - b) Turn the screw clockwise to increase the indicated amount

Note: One full turn of the screw will change the indicated amount approximately 2 liters

5. Repeat steps 1 - 4 until meter calibration is acceptable

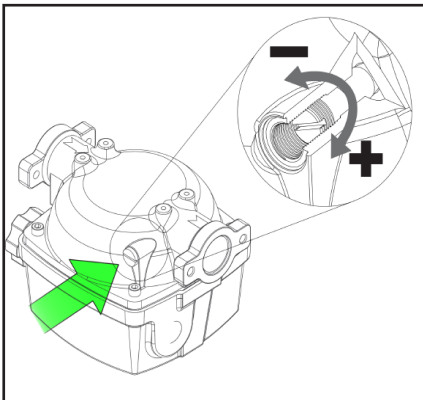

MAINTENANCE

This meter has been designed for minimum maintenance. If you have a problem with the meter please follow the trouble shooting guide in this manual or contact your local Macnaught service center or distributor.

(Register cover removal / replacement)

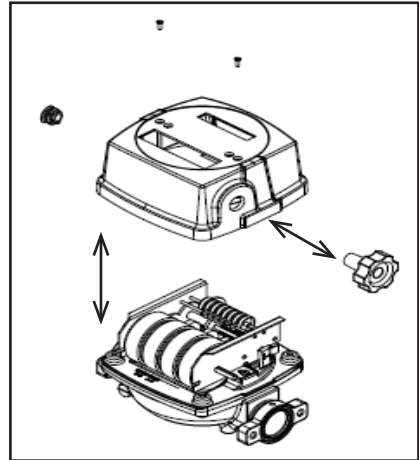

MECHANICAL DIESEL METER

AMFM

Register assembly and calibration screw
(removal / replacement)

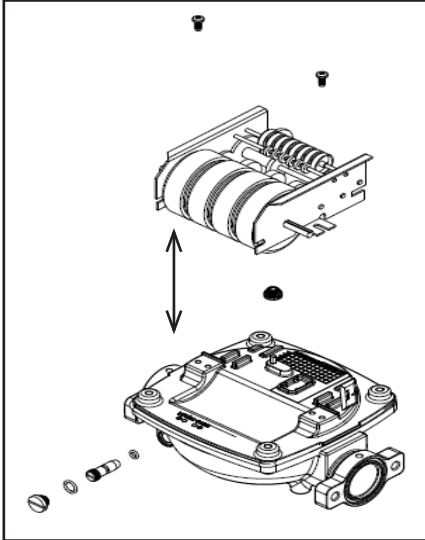

Meter body and cover-plate
(removal / replacement)

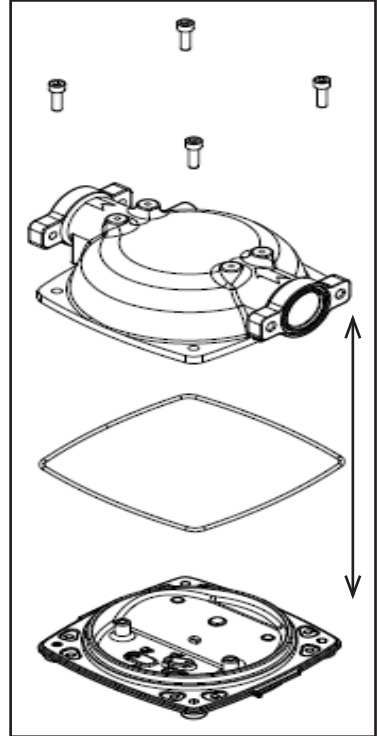

Nutating disc
(removal / replacement)

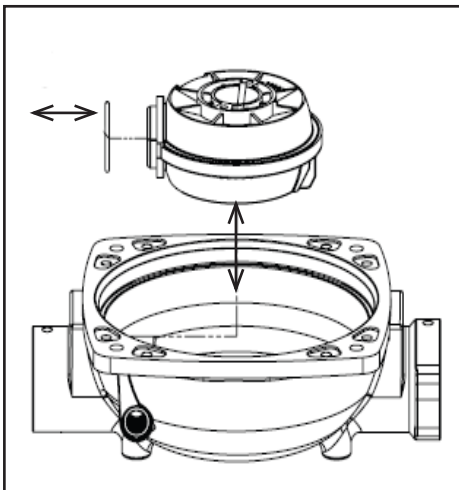

MECHANICAL DIESEL METER

AMFM

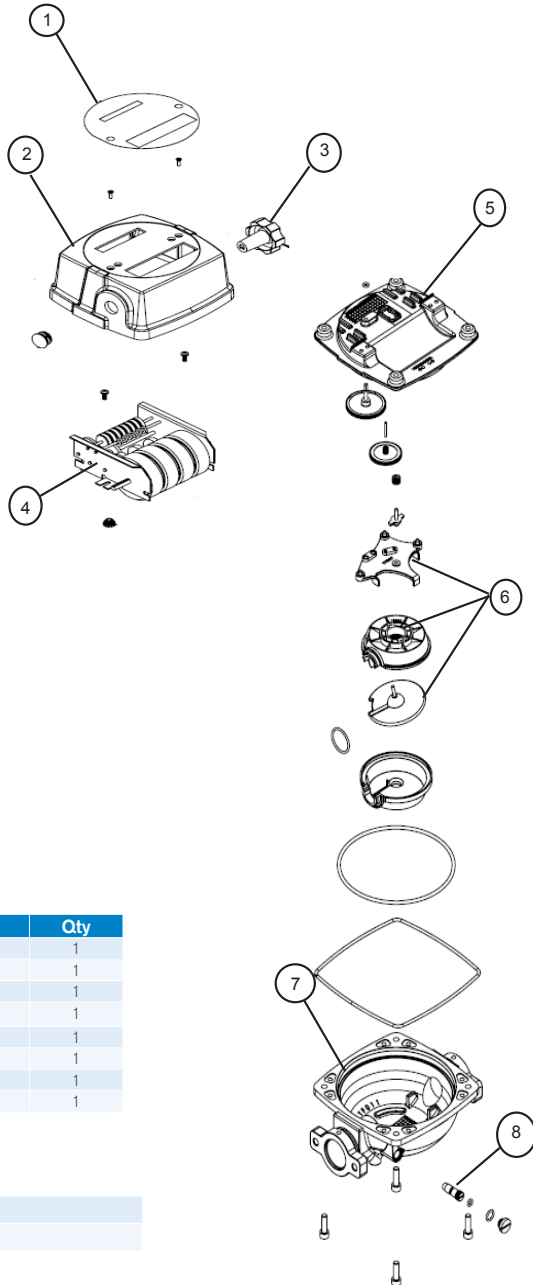

METER PARTS LIST

Item	Description	Qty
1	Fascia	1
2	Register cover	1
3	Reset knob	1
4	Register assembly	1
5	Lower cover	1
6	Nutating disc assembly	1
7	Meter body	1
8	Calibration screw	1

AVAILABLE ACCESSORIES

For seal kit order AMFM-1K

For fascia and reset button set order AMFM-2K

MECHANICAL DIESEL METER

AMFM

Gear train (removal / replacement guide)

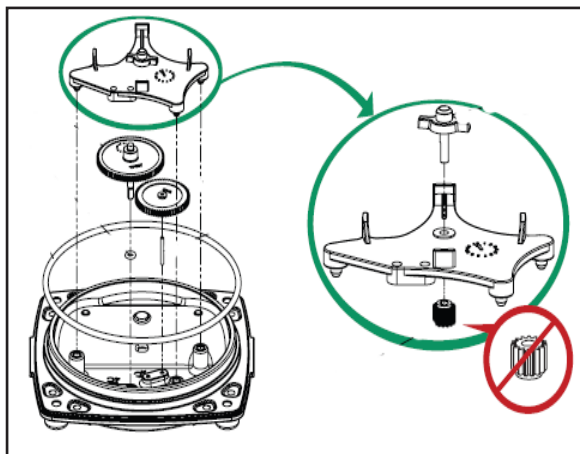

Gear replacement guide

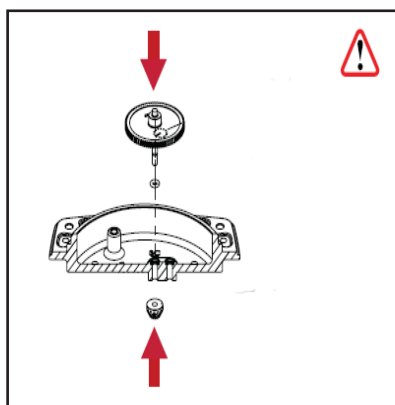

MECHANICAL DIESEL METER

AMFM

METER DIMENSIONS

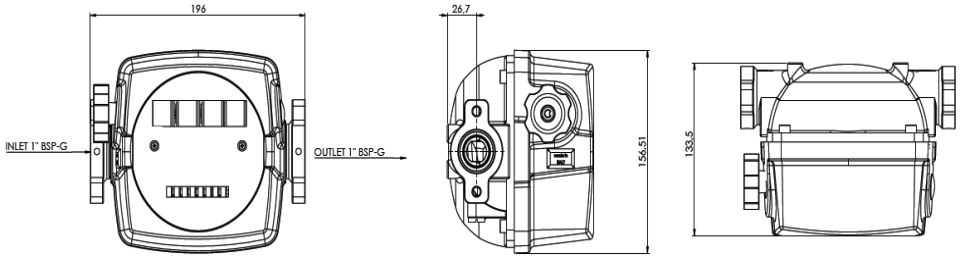

TROUBLE SHOOTING GUIDE

Problem	Cause	Solution
Meter not reading	1) Blockage in the fluid chamber	1) Clear blockage from fluid chamber
	2) Meter installed incorrectly	2) Check the meter orientation (flow must be in direction of the arrow)
Batch total does not reset	1) Reset knob not correctly engaged	1) Fit reset knob correctly
	2) Register is broken	2) Replace meter
Meter leaking	1) Damaged o'ring seal	1) Replace o'ring

METER SPECIFICATIONS

Meter Type	Nutating disc
Flow rate	20 - 120 ltr/min
Maximum pressure	3.5bar (50psi)
Accuracy	+/- 1%
Inlet / Outlet	1" BSP (F)
Temperature	-26 deg C / +66 deg C
Display	4 digit resettable totalizer ; 8 digit accumulative totalizer
Weight	1.8 kg
Fluid Compatibility	Diesel, Kerosene, Coolant
Materials of construction	POM, NBR, PPS, Aluminium, Brass, Stainless Steel



Built to last since 1948.

Macnaught Pty Ltd
41-49 Henderson Street
Turrella NSW 2205

Ph: 1800 185 102
Fax: 1800 186 402
E-mail: info@macnaught.com.au

For Warranty Terms and Conditions see www.macnaught.com.au
For a list of Australian Service Centres see www.macnaught.com.au